



### Model Number

ENA42HD-S\*\*\*-CANopen

### Features

- Solid shaft
- Up to 31 bit overall resolution
- CANopen interface
- Free of wear magnetic sampling
- High resolution and accuracy
- Highly shock / vibration and soiling resistant
- Sturdy construction
- Increased shaft load capacity
- Stainless steel housing
- IP69K

### Description

The ENA42HD series are high precision encoders with internal magnetic sampling.

This multiturn absolute encoder transmits a position value corresponding to the shaft setting via its interface.

The control module sends a start sequence to the absolute encoder to obtain the position data. The rotary encoder then sends the position data synchronous to the cycles of the control module. It is possible to select the counting direction with the function input.

### Technical data

#### General specifications

Detection type	magnetic sampling
Device type	Absolute encoders
Linearity error	$\leq \pm 0.1^\circ$

#### Functional safety related parameters

MTTF <sub>d</sub>	480 a at 40 °C
Mission Time (T <sub>M</sub> )	20 a
L <sub>10</sub>	10 E+8 revolutions
Diagnostic Coverage (DC)	0 %

#### Electrical specifications

Operating voltage U <sub>B</sub>	9 ... 30 V DC (with galvanic isolation)
Power consumption P <sub>0</sub>	$\leq 1$ W
Time delay before availability t <sub>v</sub>	< 250 ms
Output code	binary code
Code course (counting direction)	adjustable

#### Interface

Interface type	CANopen
----------------	---------

#### Resolution

Single turn	up to 16 Bit
Multiturn	up to 15 Bit
Overall resolution	up to 31 Bit

Transfer rate	min. 20 kBit/s , max. 1 MBit/s
Cycle time	$\geq 1$ ms
Standard conformity	DSP 406

#### Connection

Connector	M12 connector, 5 pin
Cable	$\varnothing 6$ mm, 4 x 2 x 0.14 mm <sup>2</sup>

#### Standard conformity

Degree of protection	DIN EN 60529 , IP66 / IP68 / IP69K
Climatic testing	DIN EN 60068-2-3, no moisture condensation
Emitted interference	EN 61000-6-4:2007
Noise immunity	EN 61000-6-2:2005
Shock resistance	DIN EN 60068-2-27, 300 g, 6 ms
Vibration resistance	DIN EN 60068-2-6, 30 g, 10 ... 1000 Hz

#### Ambient conditions

Operating temperature	-40 ... 85 °C (-40 ... 185 °F)
Storage temperature	-40 ... 85 °C (-40 ... 185 °F)
Relative humidity	98 % , no moisture condensation

#### Mechanical specifications

Material	
Housing	stainless steel 1.4404 / AISI 316L
Flange	stainless steel 1.4404 / AISI 316L
Shaft	Stainless steel 1.4412 / AISI 440B
Mass	approx. 350 g
Rotational speed	max. 6000 min <sup>-1</sup>
Moment of inertia	30 gcm <sup>2</sup>
Starting torque	< 5 Ncm
Shaft load	
Axial	270 N
Radial	270 N

Dimensions

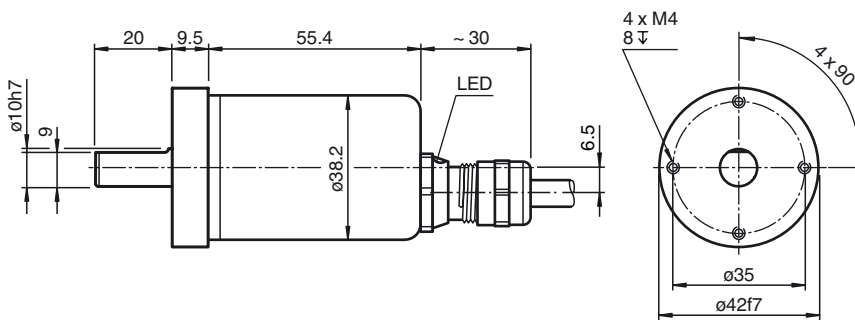
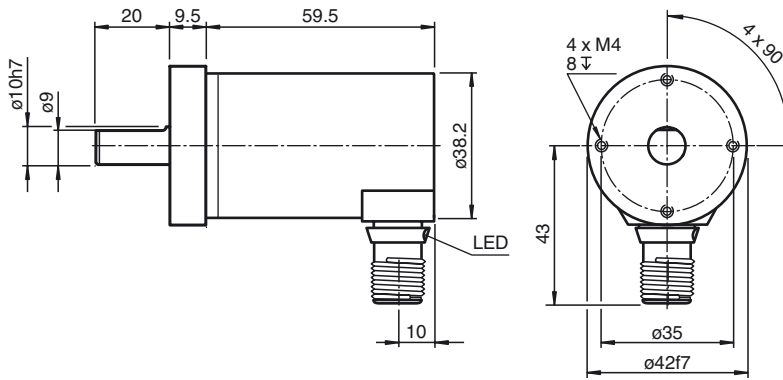
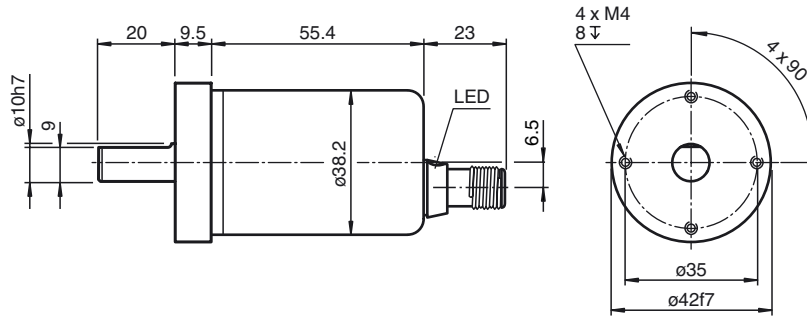

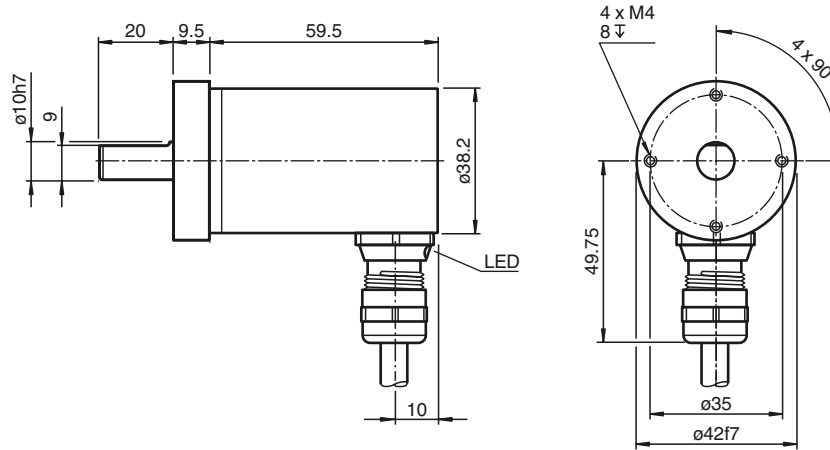

**Electrical connection**

Signal	Wire end	5-pin, M12 x 1 connector
CAN GND	green	1
+V <sub>S</sub>	red	2
GND	yellow	3
CAN-High	white	4
CAN-Low	brown	5
Shielding	Shielding	Housing
Pinout		

## Indicating elements

### LED-indicator with dual color LED

CAN Run (green)	State	Description
Blinking	Pre-Operational	Boot up message is sent, device configuration is possible, device is in CAN state „Pre-Operational“
Single flash	Stopped	The Encoder is in CAN state „Stopped“
On	Operational	The encoder is in CAN state „Operational“
Off		No power supply
Err (red)	State	Description
Off	No error	The Encoder is in operating mode
Flickering	AutoBaudrate	Auto baud mode is active and the encoder tries to find within the time out period a valid CAN message for baud rate measurement
Single flash	Warning limit reached	At least one of the error counters of the CAN controller has reached or exceeded the warning level (too many error frames)
Double flash	Error control event	A guard event (NTM slave or NTM master) or a heartbeat event has occurred
On	Bus off	The CAN controller is in stae bus off. No communication possible anymore. Too many error frames in the network.

**Programmable CAN operating modes**

Mode	Explanation
Polled mode	The connected host requests the current actual position value via a remote transmission request telegram. The absolute encoder reads in the current position, calculates all parameters that have been set and sends back the process actual value through the same CAN identifier.
Cyclic mode	The absolute encoder sends the current actual process value cyclically, without being prompted by the host. The cycle time can be programmed in milliseconds for values between 1 ms and 65536 ms.
Sync mode	After the sync telegram has been received by the host, the absolute encoder sends the current actual process value. If multiple nodes should respond to the sync telegram, the individual nodes report one after the other according to their CAN identifier. There is no programming of an offset time. The sync counter can be programmed so that the rotary encoder does not transmit until after a defined number of sync telegrams.

**Programmable rotary encoder parameters**

Parameter	Explanation
Operating parameter	The direction of rotation (complement) can be specified by parameter as the operating parameter. This parameter determines the direction of rotation in which the output code will ascend or descend.
Resolution per revolution	The "Resolution" parameter is used to program the rotary encoder so that a desired number of steps can be implemented in reference to one revolution.
Preset value	The preset value is the desired position value that must be achieved for a specific physical setting of the axis. The preset value parameter is used to set the actual position value to the desired actual process value.
Min. and max. limit switch	A total of two positions can be programmed. The absolute encoder sets one bit to high state in the 32 Bit actual process value if a value falls outside the range between these two positions.
Cam	8 freely programmable cams can be set within the overall resolution. This produces the functionality of a mechanical cam shifting mechanism.

Model number

**E N A 4 2 H D - S 1 0 S 4 9 - - - - B 1 6 - - -**

